

# LUMEN FOCUS FFR KIT WITH EM PACK INSTALL INSTRUCTIONS

CAUTION: THE INSTALLATION AND SERVICING OF THIS PRODUCT SHOULD BE PERFORMED BY A QUALIFIED ELECTRICIAN OR SERVICE PERSONNEL

WARNING - RISK OF FIRE OR ELECTRIC SHOCK. INSTALL THIS KIT ONLY IN LUMINAIRES THAT HAVE THE CONSTRUCTION FEATURES AND / OR DRAWINGS AND WHERE THE INPUT RATING OF THE REROFIT KIT DOES NOT EXCEED THE INPUT RATING OF THE LUMINAIRE.

WARNING - TO PREVENT WIRING DAMAGE OR ABRASION, DO NOT EXPOSE WIRING TO EDGES OF SHEET METAL OR OTHER SHARP OBJECTS.

WARNING - RISK OF FIRE OR ELECTRIC SHOCK, LUMINAIRE WIRING AND ELECTRICAL PARTS MAY BE DAMAGED WHEN DRILLING FOR INSTALLATION OF LED RETROFIT KIT. CHECK FOR ENCLOSED WIRING AND COMPONENTS.

CAUTION: UNLESS OTHERWISE INDICATED, DO NOT MAKE OR ALTER ANY OPENINGS IN THE COMPARTMENT OF WIRING OR ELECTRICAL DURING INSTALLATION OF THIS RETROFIT ASSEMBLY. PLUG ALL UNUSED OPENINGS IN THE COMPARTMENT OF WIRING OR ELECTRICAL COMPONENTS.

\*DO NOT MAKE OR ALTER ANY OPEN HOLES IN AN ENCLOSURE OF WIRING OR ELECTRICAL COMPONENTS DURING KIT INSTALLATION.

WARNING - RISK OF FIRE, ELECTRIC SHOCK, OR PERSONAL INJURY. BEFORE INSTALLATION TURN POWER OFF.

WARNING - RISK OF FIRE OR ELECTRIC SHOCK, LED RETROFIT KIT INSTALLATION REQUIRES KNOWLEDGE OF LUMINAIRES ELECTRICAL SYSTEMS. IF NOT QUALIFIED DO NOT ATTEMPT INSTALLATION. CONTACT A QUALIFIED ELECTRICIAN.

## REMOVAL PROCESS

1. TURN OFF POWER
2. REMOVE LENS / DOORFRAME FROM FIXTURE
3. REMOVE LAMPS(RECYCLE AS NEEDED)
4. REMOVE FLUORESCENT REFLECTOR, BALLAST, SOCKETBARS AND EXCESS WIRING FROM FIXTURE

2X4 KIT SHOWN

## FIXTURE IN CEILING GRID

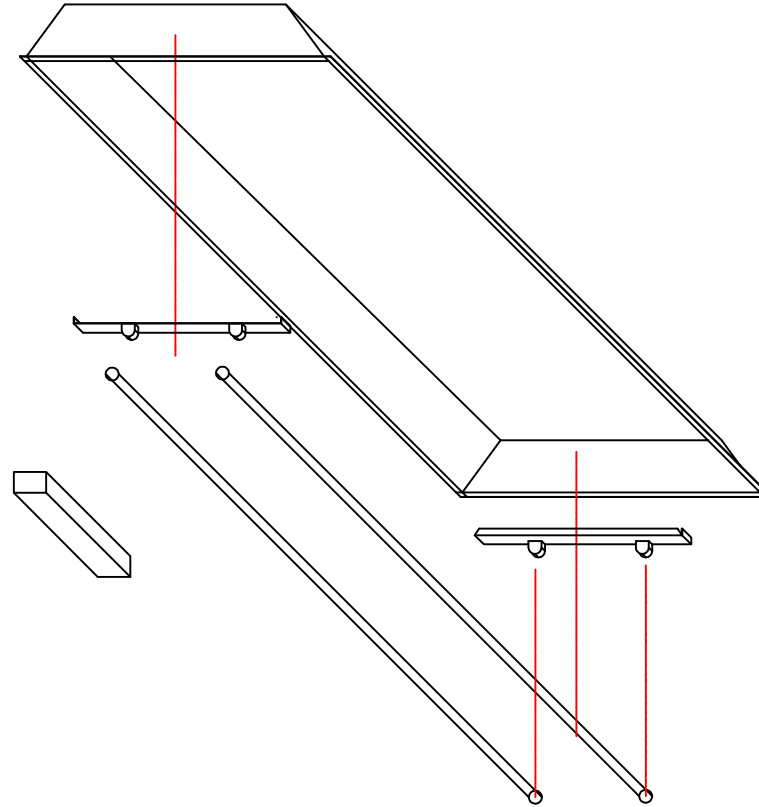

# LUMEN FOCUS FFR KIT WITH EM PACK INSTALL INSTRUCTIONS

CAUTION: THE INSTALLATION AND SERVICING OF THIS PRODUCT SHOULD BE PERFORMED BY A QUALIFIED ELECTRICIAN OR SERVICE PERSONNEL

WARNING - RISK OF FIRE OR ELECTRIC SHOCK. INSTALL THIS KIT ONLY IN LUMINAIRES THAT HAVE THE CONSTRUCTION FEATURES AND / OR DRAWINGS AND WHERE THE INPUT RATING OF THE REROFIT KIT DOES NOT EXCEED THE INPUT RATING OF THE LUMINAIRE.

WARNING - TO PREVENT WIRING DAMAGE OR ABRASION, DO NOT EXPOSE WIRING TO EDGES OF SHEET METAL OR OTHER SHARP OBJECTS.

WARNING - RISK OF FIRE OR ELECTRIC SHOCK, LUMINAIRE WIRING AND ELECTRICAL PARTS MAY BE DAMAGED WHEN DRILLING FOR INSTALLATION OF LED RETROFIT KIT. CHECK FOR ENCLOSED WIRING AND COMPONENTS.

CAUTION: UNLESS OTHERWISE INDICATED, DO NOT MAKE OR ALTER ANY OPENINGS IN THE COMPARTMENT OF WIRING OR ELECTRICAL DURING INSTALLATION OF THIS RETROFIT ASSEMBLY. PLUG ALL UNUSED OPENINGS IN THE COMPARTMENT OF WIRING OR ELECTRICAL COMPONENTS.

WARNING - RISK OF FIRE, ELECTRIC SHOCK, OR PERSONAL INJURY. BEFORE INSTALLATION TURN POWER OFF.

WARNING - RISK OF FIRE OR ELECTRIC SHOCK, LED RETROFIT KIT INSTALLATION REQUIRES KNOWLEDGE OF LUMINAIRE ELECTRICAL SYSTEMS. IF NOT QUALIFIED DO NOT ATTEMPT INSTALLATION. CONTACT A QUALIFIED ELECTRICIAN.

KIT INCLUDES		
QTY.	PART NUMBER	ITEM
1	FFR ENDCAP LEFT HAND	A1
1	FFR ENDCAP RIGHT HAND	A2
1	FFR LED PANEL	B
1	FFR BLANK PANEL	C
2	QUARTER TURNS	D
2	SAFETY STRAPS	E
2	SELF-TAPPING SCREWS	F
4	TEK-SCREWS	G
1	LENS	H
1	873-902 DISCONNECT	I

SEE PAGE #3  
SEE PAGE #3

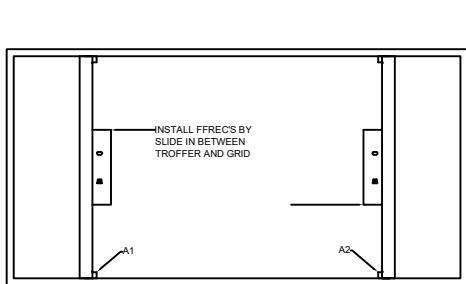

1. PLACE FFR ENDCAP AT EACH END OF THE

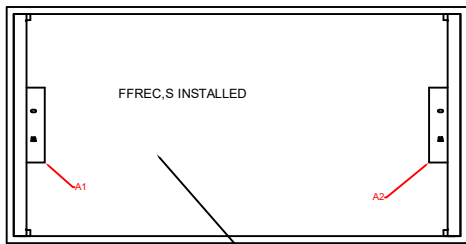

INSTALL LUMINAIRE MODIFICATION LABEL PROVIDED IN KIT

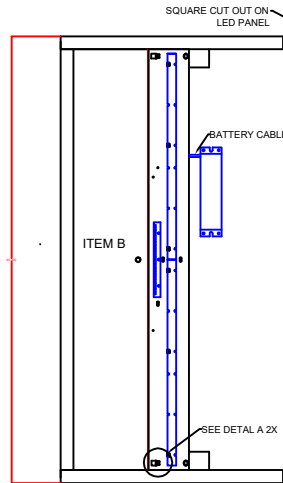

2. SLIDE LED PANEL BETWEEN GRID AND TROFFER FASTEN USING SQ CUT OUT ON LED PANNEL AND FORM TAB ON ENDCAP SEE DETAL A
3. INSTALL EMERGENCY BATTERY PACK IN APPROXIMATE LOCATION SHOWN IN TROFFER USING THE PROVIDED TEK SCREWS (2) CONNECT BATTERY CABLE TO EMERGENCY DRIVER ON FFR24LED PANEL
4. CONNECT LED PANEL ELECTRICAL WITH PROVIDED DISCONNECT WHITE(NEUTRAL) TO WHITE, BLACK(POWER FEED) TO BLACK CONNECT GREEN GROUND TO FIXTURE BACK WITH PROVIDED SCREW
5. INSTALL SAFETY-STRAP AT EACH END OF FIXTURE  
1 SELF-TAPPING SCREW USED TO ATTACH STRAP TO ENDCAP  
CONNECT OTHER END OF SAFETY-STRAP TO FIXTURE USING TEK-SCREW  
ALL SCREWS ARE PROVIDED IN KIT.

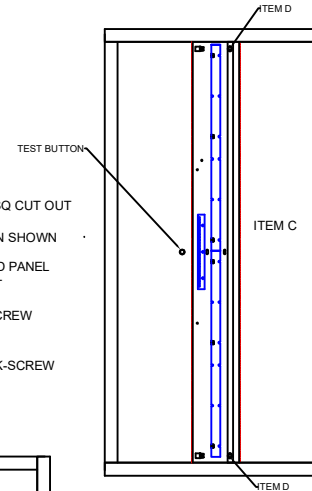
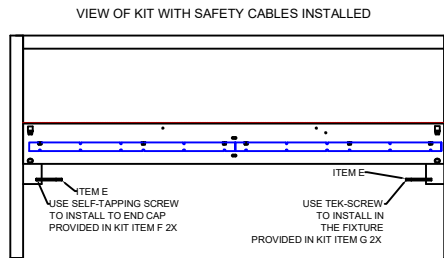

6. SLIDE BLANK PANEL BETWEEN GRID AND TROFFER FASTEN WITH PROVIDED QUARTER TURNS ITEM D 2X

# LUMEN FOCUS FFR KIT WITH EM PACK INSTALL INSTRUCTIONS

CAUTION: THE INSTALLATION AND SERVICING OF THIS PRODUCT SHOULD BE PERFORMED BY A QUALIFIED ELECTRICIAN OR SERVICE PERSONNEL

WARNING - RISK OF FIRE OR ELECTRIC SHOCK. INSTALL THIS KIT ONLY IN LUMINAIRES THAT HAVE THE CONSTRUCTION FEATURES AND / OR DRAWINGS AND WHERE THE INPUT RATING OF THE RETROFIT KIT DOES NOT EXCEED THE INPUT RATING OF THE LUMINAIRE.

WARNING - TO PREVENT WIRING DAMAGE OR ABRASION, DO NOT EXPOSE WIRING TO EDGES OF SHEET METAL OR OTHER SHARP OBJECTS.

WARNING - RISK OF FIRE OR ELECTRIC SHOCK, LUMINAIRE WIRING AND ELECTRICAL PARTS MAY BE DAMAGED WHEN DRILLING FOR INSTALLATION OF LED RETROFIT KIT. CHECK FOR ENCLOSED WIRING AND COMPONENTS.

CAUTION: UNLESS OTHERWISE INDICATED, DO NOT MAKE OR ALTER ANY OPENINGS IN THE COMPARTMENT OF WIRING OR ELECTRICAL DURING INSTALLATION OF THIS RETROFIT ASSEMBLY. PLUG ALL UNUSED OPENINGS IN THE COMPARTMENT OF WIRING OR ELECTRICAL COMPONENTS.

WARNING - RISK OF FIRE, ELECTRIC SHOCK, OR PERSONAL INJURY. BEFORE INSTALLATION TURN POWER OFF.

WARNING - RISK OF FIRE OR ELECTRIC SHOCK, LED RETROFIT KIT INSTALLATION REQUIRES KNOWLEDGE OF LUMINAIRE ELECTRICAL SYSTEMS. IF NOT QUALIFIED DO NOT ATTEMPT INSTALLATION. CONTACT A QUALIFIED ELECTRICIAN.

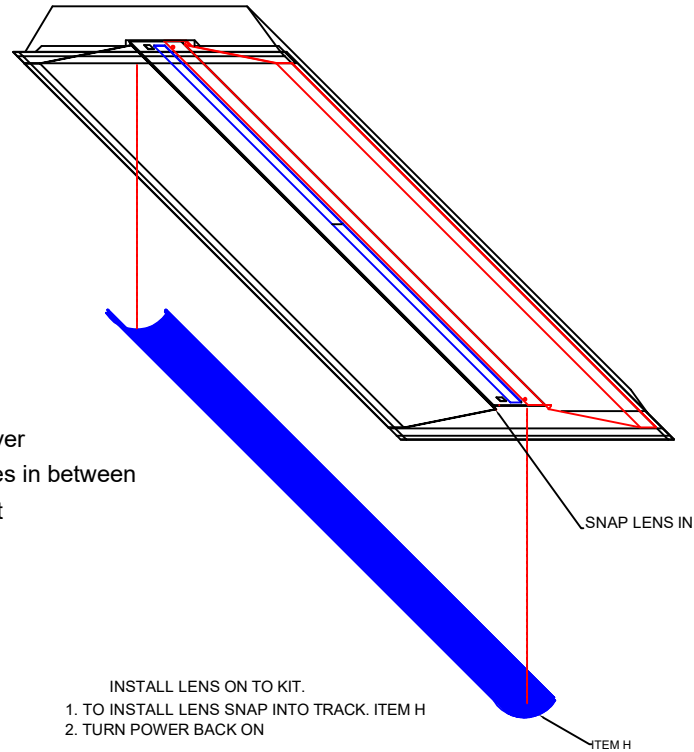

## WIRE SCHEMATIC

Line side input to driver  
120V to 277V and all voltages in between  
120V - 277V input

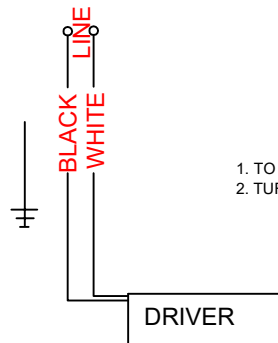

INSTALL LENS ON TO KIT.  
1. TO INSTALL LENS SNAP INTO TRACK. ITEM H  
2. TURN POWER BACK ON