

# LUMEN FOCUS FFR KIT INSTALL INSTRUCTIONS

CAUTION: THE INSTALLATION AND SERVICING OF THIS PRODUCT SHOULD BE PERFORMED BY A QUALIFIED ELECTRICIAN OR SERVICE PERSONNEL  
 "DO NOT MAKE OR ALTER ANY OPEN HOLES IN AN ENCLOSURE OF WIRING OR ELECTRICAL COMPONENTS DURING KIT INSTALLATION"

## REMOVAL PROCESS

1. TURN OFF POWER
2. REMOVE LENS / DOORFRAME FROM FIXTURE
3. REMOVE LAMPS(RECYCLE AS NEEDED)
4. REMOVE FLUORESCENT REFLECTOR, BALLAST, SOCKETBARS AND EXCESS WIRING FROM FIXTURE



## WARNING - RISK OF FIRE OR ELECTRIC SHOCK.

INSTALL THIS KIT ONLY IN LUMINAIRES THAT HAVE THE CONSTRUCTION FEATURES AND / OR DRAWINGS AND WHERE THE INPUT RATING OF THE REROFIT KIT DOES NOT EXCEED THE INPUT RATING OF THE LUMINAIRE.

WARNING - TO PREVENT WIRING DAMAGE OR ABRASION, DO NOT EXPOSE WIRING TO EDGES OF SHEET METAL OR OTHER SHARP OBJECTS.

WARNING - RISK OF FIRE OR ELECTRIC SHOCK, LUMINAIRE WIRING AND ELECTRICAL PARTS MAY BE DAMAGED WHEN DRILLING FOR INSTALLATION OF LED RETROFIT KIT. CHECK FOR ENCLOSED WIRING AND COMPONENTS.

CAUTION: UNLESS OTHERWISE INDICATED, DO NOT MAKE OR ALTER ANY OPENINGS IN THE COMPARTMENT OF WIRING OR ELECTRICAL DURING INSTALLATION OF THIS RETROFIT ASSEMBLY. PLUG ALL UNUSED OPENINGS IN THE COMPARTMENT OF WIRING OR ELECTRICAL COMPONENTS.

WARNING - RISK OF FIRE, ELECTRIC SHOCK, OR PERSONAL INJURY. BEFORE INSTALLATION TURN POWER OFF.

WARNING - RISK OF FIRE OR ELECTRIC SHOCK, LED RETROFIT KIT INSTALLATION REQUIRES KNOWLEDGE OF LUMINAIRE ELECTRICAL SYSTEMS. IF NOT QUALIFIED DO NOT ATTEMPT INSTALLATION. CONTACT A QUALIFIED ELECTRICIAN.

2X4 KIT SHOWN  
 FIXTURE IN CEILING GRID

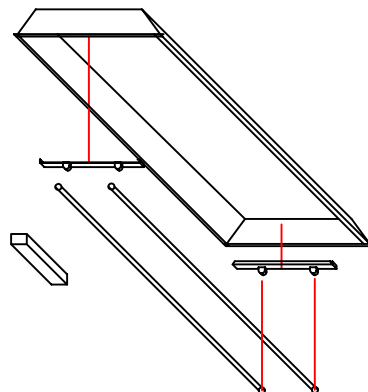

## KIT INCLUDES

QTY.	PART NUMBER.	ITEM
1	FFR ENDCAP LEFT HAND	A1
1	FFR ENDCAP RIGHT HAND	A2
1	FFR LED PANEL	B
1	FFR BLANK PANEL	C
2	QUARTER TURNS	D
2	SAFETY STRAPS	E
2	SELF-TAPPING SCREWS	F
2	TEK-SCREWS	G
1	LENS	H
1	873-902 DISCONNECT	I

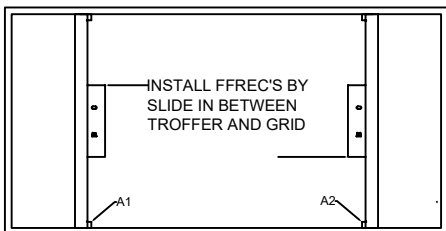

1. PLACE FFR ENDCAP AT EACH END OF THE TROFFER

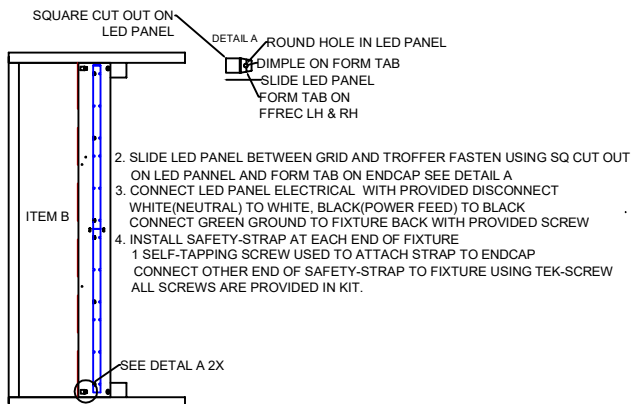

VIEW OF KIT WITH SAFETY CABLES INSTALLED

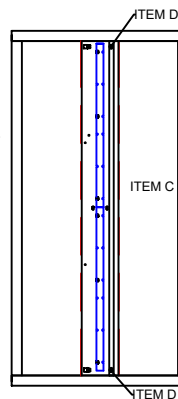

5. SLIDE BLANK PANEL BETWEEN GRID AND TROFFER FASTEN WITH PROVIDED QUARTER TURNS ITEM D 2X

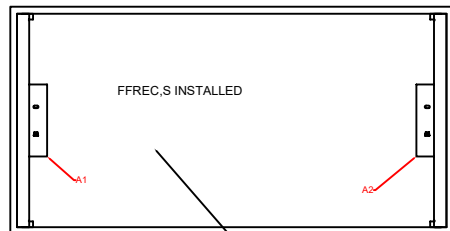

INSTALL LUMINAIRE MODIFICATION LABEL PROVIDED IN KIT

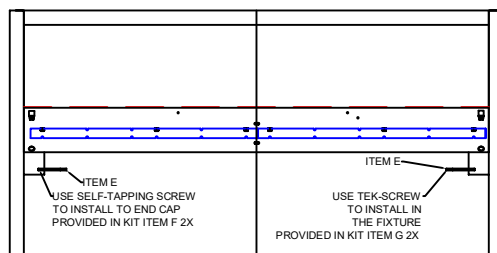

## WIRE SCHEMATIC

Line side input to driver  
 120V to 277V and all voltages in between  
 120V - 277V input

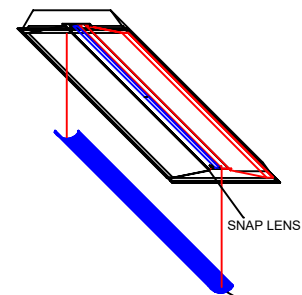
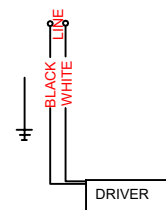

INSTALL LENS ON TO KIT.  
 1. TO INSTALL LENS SNAP INTO TRACK. ITEM H  
 2. TURN POWER BACK ON



ITEM I