



**ANTI-VIRAL  
ANTI-BACTERIAL**

Project: \_\_\_\_\_  
 Location: \_\_\_\_\_  
 Cat. #: \_\_\_\_\_  
 Type: \_\_\_\_\_  
 Quantity: \_\_\_\_\_

**LED**

**GAC** LED Germicidal Air Chamber with down light

**Features:**

- Anti-viral and anti-bacterial disinfection lighting in a lay-in fixture
- Surface disinfection out of the front, purification out of the back - fan and chamber work to kill airborne pathogens (viruses, including COVID-19 and SARS), spores and any other living organism that passes through
- Two fan options: normal speed for quieter applications and high speed for greater airflow
- Carbon filter catches all leftover fine particulates
- High performance disinfecting LED technology utilizing IllumiPure LEDs
- Continuously disinfect any hard or soft surfaces simply by keeping the lights on
- Effective against MRSA, C. Difficile, Salmonella, E. Coli
- Down lighting completely harmless to humans and animals as the antibacterial spectrum is part of the normal visible LED spectrum
- Dimming for down light available
- UV chamber mounted in the back of the fixture pulls in air via surface-mounted fans. Air pulled into chamber is cleansed of airborne pathogens (viruses and bacteria) utilizing 260-265nm UVC with a 99-plus % inactivation rate. All viruses are known to be affected by UVC, however, inactivation time varies from virus to virus
- IoT option available

**Applications:**

- Suitable for most commercial and institutional applications. May be placed in room, plenum or return duct.
- Office
  - Retail
  - Classrooms
  - Healthcare Facilities

**Predicted Lifetime:**

- Fixture lifespan: >50,000 hrs
- Disinfection chamber lifespan: >35,000 hrs

**Construction:**

- Aluminum housing
- Lens constructed of proprietary polycarbonate

**Certifications:**

- CE and UL pending
- Patent pending

**Warranty:**

- 405nm LED boards for downlight: 4 years
- 260-265nm LED boards in back chamber: 30,000 hours
- Fans: 3 years
- Balance of fixture: 10 years



**Ordering Guide:**

example: GAC 22 HI UV FP HF 850

Series	Size	Output	Voltage	Fan	Shielding	CRI/CCT	-	Options
GAC		HI	UV		FP		-	
GAC	22 24	HI	UV	Blank HF	FP	842 845 850		Blank W6 W10 D IoT

<b>Size:</b>	22 2'x2' 24 2'x4'	<b>CRI/CCT:</b>	842 80 CRI / 4200K 845 80 CRI / 4500K 850 80 CRI / 5000K
<b>Lumen Output:</b>	HI High	<b>Options:</b>	Blank None W6 6' Whip W10 10' Whip D Dimming IoT IoT-ready controls (Contact factory for details)
<b>Voltage:</b>	UV 120-277V		
<b>Fan:</b>	Blank Normal Volume HF High Flow		
<b>Shielding:</b>	FP Frosted Polycarbonate		

**Performance Chart:**

Catalog #	Watts	Watts (Disinfection Chamber)	Fan CFM	Lumens (842)	LPW (842)	Lumens (845)	LPW (845)	Lumens (850)	LPW (850)
GAC 22 HI UV FP 8xx	60	18	70	6900	115	6900	115	6900	115
GAC 22 HI UV HF FP 8xx	60	18	100	6900	115	6900	115	6900	115
GAC 24 HI UV FP 8xx	78	36	140	8970	115	8970	115	8970	115
GAC 24 HI UV HF FP 8xx	78	36	200	8970	115	8970	115	8970	115

**Wavelength (Down light):**

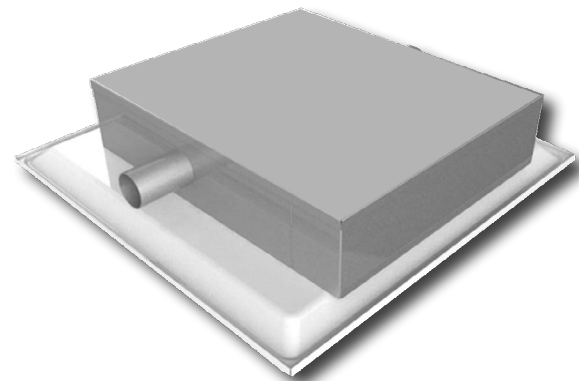
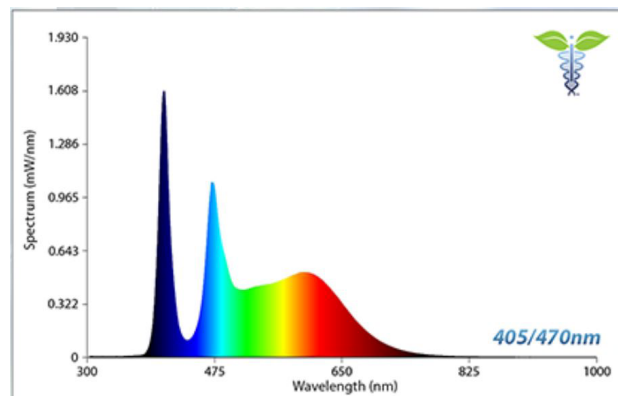

**Schematics:**

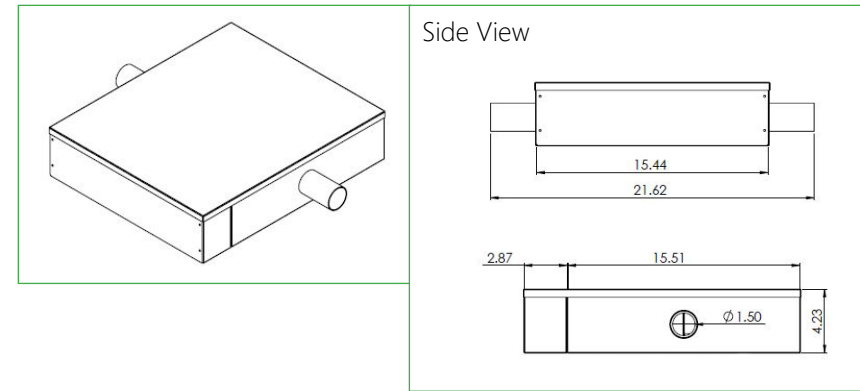

**Notes:**

Fan in 2x2 unit pulls in air at 73 or 100 CFM; dual fans in 2x4 unit pull in air at 146 or 200 CFM, depending on fan option selected (exhaust ports need to be 6 feet from fixture). The GAC produces six air changes per hour (ACH) for a 300 square-foot room with 8-foot ceiling; 4 ACH for 400 square-foot room with 8-foot ceiling (see page 4 for more details).

**Air changes per hour:**

The table below shows the number of air changes per hour (ACH) and time in minutes required for removal efficiencies of 90%, 99% and 99.9% of airborne contaminants.

ACH	Minutes required for a removal efficiency of:		
	90%	99%	99.9%
1	138	276	414
2	69	138	207
3	46	92	138
4	35	69	104
5	28	55	83
6	23	46	69
7	20	39	59
8	17	35	52
9	15	31	46
10	14	28	41
11	13	25	38
12	12	23	35
13	11	21	32
14	10	20	30
15	9	18	28

This table has been adapted from the formula for the rate of purging airborne contaminants (99). Values have been derived from the formula  $t_1 = [\ln(C_2 \div C_1) \div (Q \div V)] \times 60$ , with  $T_1 = 0$  and  $C_2 \div C_1$  - (removal efficiency  $\div$  100), and where:

- $t_1$  = initial timepoint
- $C_1$  = initial concentration of contaminant
- $C_2$  = final concentration of contaminants
- $Q$  = air flow rate (cubic feet per hour)
- $V$  = room volume (cubic feet)
- $Q \div V = ACH$

The times given assume perfect mixing of the air within the space (i.e., mixing factor = 1). However, perfect mixing usually does not occur, and the mixing factor could be as high as 10 if the air distribution is very poor (98). The required time is derived by multiplying the appropriate time from the table by the mixing factor that has been determined for the booth or room.

**Total exposed surface area of titanium dioxide (UVC disinfection) within GAC box: <19 feet. Total length covered by air in GAC box: <18 feet.**

**KILL > 99% OF COVID-19**



**Note:** UVFocus products are designed utilizing proven germicidal and anti-bacterial technology. UVC 254nm and 260-265nm products work to deactivate most common viruses (as well as bacteria, molds and yeasts), and 405nm near-UV products are shown to substantially reduce bacterial presence. While these products can be considered disinfecting products, they should be used in conjunction with standard, proper disinfecting cleaning procedures to have the greatest impact for maintaining a clean environment. Successful UV disinfection requires a systems approach taking into account dose, optics and safety relevant to the specific application. Please consult with factory any questions or concerns.